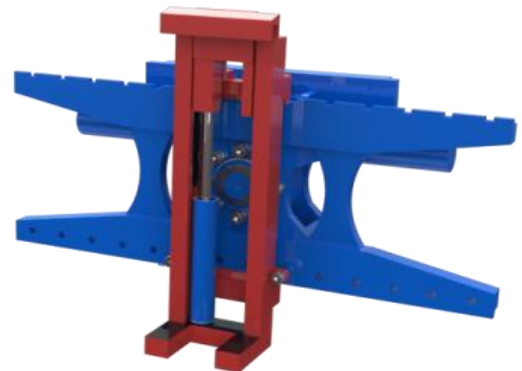
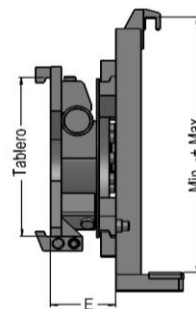
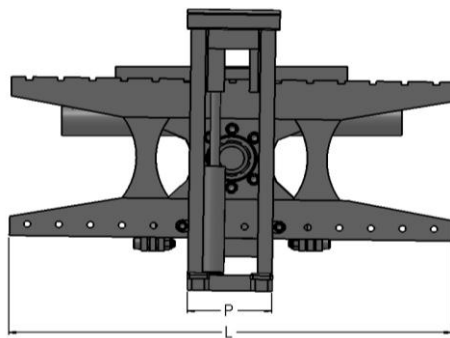

Modelo	Tablero	Tipo contene	Gama		Capacidad	c.d.g.	Dist.horquilla:		Espesor	Peso	c.d.g.	P.V.P.
			Max-Min	aperturas			Kilos	mm.				
TGL1-HGV -1-800	FEM II	1	495-880		1500	500	680	800	213	249	190	4.428
TGL1-HGV -2-800	FEM II	2	320-470		1500	500	680	800	213	243	187	4.486
TGL1-HGV -1-1000	FEM II	1	495-880		1500	500	680	1000	213	261	260	4.433
TGL1-HGV -2-1000	FEM II	2	320-470		1500	500	680	1000	213	255	248	4.491
TGL1-HGV -1-1200	FEM II	1	495-880		1500	500	680	1200	213	273	277	4.449
TGL1-HGV -2-1200	FEM II	2	320-470		1500	500	680	1200	213	267	274	4.505

**GIRATORIO CON MASTIL-GRAPA VERTICAL
ROTATOR WITH STABILIZER**

Modelo	Tablero	Tipo conti	Gama		Capacidad	c.d.g.	Longitud	Ancho ale	Espesor	Peso	c.d.g.	P.V.P.
			Max-Min	aperturas								
TGL1-GV -1	FEM II	1	495-880		1.500	500	1050	200	213	209	109	4.178
TGL1-GV -2	FEM II	2	320-470		1.500	500	1050	100	213	206	107	4.236

tipo 1	contendor	exterior	interior
	alto		
	máximo	850	690
tipo 2	mínimo	655	520
	máximo	600	450
	mínimo	490	340

La adición sobre un tablero giratorio de 180° estándar, con alimentación hidráulica a través de válvula giratoria central, ya sea con horquillas con grapa o mástil con grapa, permiten el volteo de contenedores abiertos por debajo, el equipo incorpora válvula de secuencia, para funcionar con un solo mando. (caudal ajustado a 12-15 litros)