

IP 65

230 - 400 V

-20/+ 60 °C

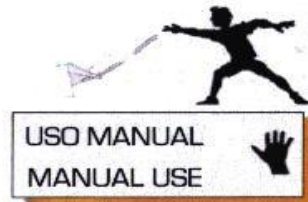
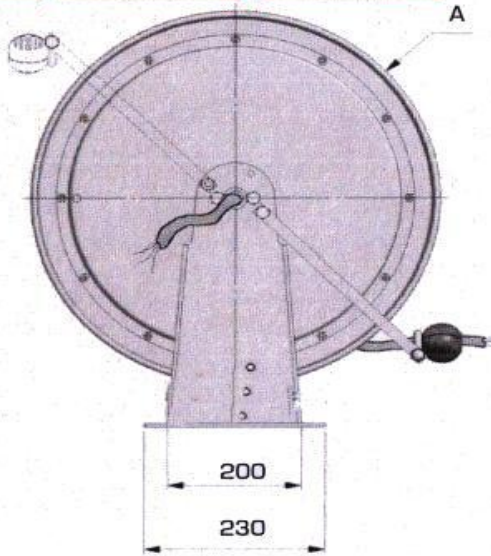

USO MANUAL
MANUAL USE

Cable / cavo			V	Colector Slip-ring 30 Amp.	W		A	B	C	D	CODIGO CODE	PRECIO PRICE EURIO		
Tipo Type	D mm.	m											mm	
3 x 1.5	8,0	10	230	2F+T	1,2	3,5	478	57	540		531			
		20									532			
		30									533			
3 x 2.5	10,2	10	230	2F+T	1,8	5,5	478	67	540		537	1.118,00		
		20									538	1.295,00		
		30									539	1.392,00		
4 x 1.5	9,3	10	400	3F+T	4	6	478	57	540		543			
		20			3	5					544			
		30									545			
4 x 2.5	10,7	10	400	3F+T	7	9	478	80	540		549			
		20			6	8					550			
		30									551	1.927,00		
4 x 4	15,0	10	400	3F+T	11	15	478	92	540		555	1.782,00		
		20			9	13					520	580	556	
		30											557	2.311,00
4 x 6	14,5	10	400	3F+T	17	22	478	92	540		561			
		20									520	580	562	
		30											563	3.267,00
5 x 1.5	10,0	10	400	3F+T+N	4	6	478	67	540		567			
		20			3	5					568			
		30									569			
5 x 2.5	13,0	10	400	3F+T+N	7	9	478	80	540		573			
		20			6	8					520	580	574	
		30											575	
5 x 4	16,2	10	400	3F+T+N	11	15	478	83	540		579			
		20			9	13					520	580	580	2.942,00
		30											581	



Automático con dispositivo de traba de cable y soporte giratorio
Auto roller cable reel with cable lock and mounting bracket

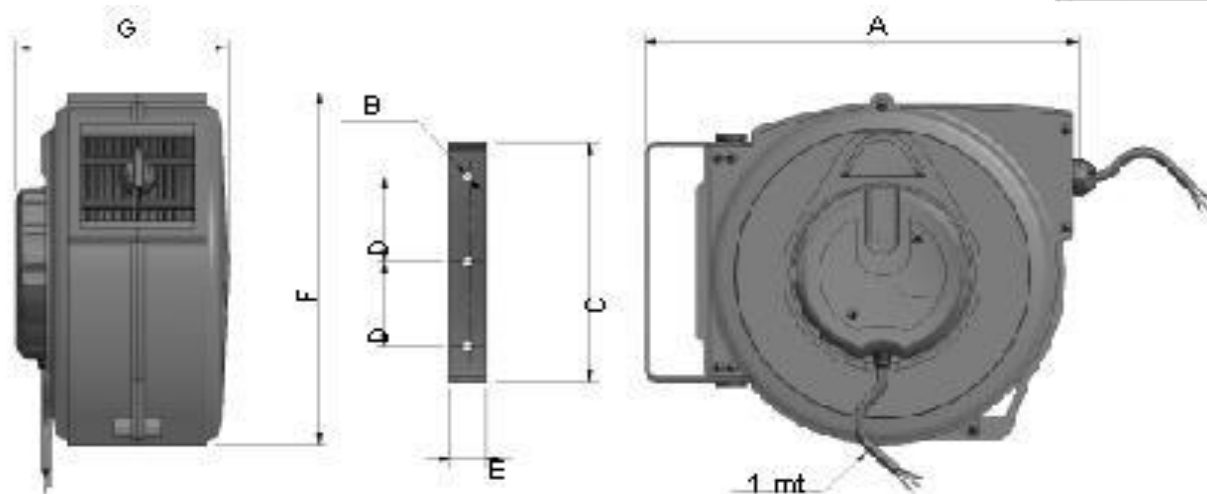

CODIGO - CODE	ART.	CABLE	m	V	W		A	B	C	D	E	F	G	PRECIO PRICE EURO	PESO WEIGHT Kg
811001	701	1x6	15	2.5 KW max.			320	8	190	70	30	250	160	293,00	5
800200	710	2x1	7	230	800	2000	220	8	156	50	30	185	135	166,00	4
811180	711		15	230	800	1400	320	8	190	70	30	250	150	215,00	7
811230	713		15	12	60	60	320	8	190	70	30	250	160	316,00	6,5
811220	713		15	24	60	60	320	8	190	70	30	250	160	316,00	6,5
800100	720		3x1,5	5	230	800	2000	220	8	156	50	30	185	135	186,00
811190	721	10		800		2000	320	8	190	70	30	250	160	248,00	4,5
811020	722	15		800		2000	320	8	190	70	30	250	160	288,00	5,1
807004	723	25		800		2000	450	8	190	70	30	361	195	477,00	8,5
880400	724	35		800		2000	530	8	190	70	30	425	210	573,00	10
807225	740	5x1,5	20	380	1000	3000	420	8	340	105	40	350	210	605,00	9
880600	741	5x1,5	30	380	1000	3000	530	8	190	70	30	425	210	728,00	11



Automático, con dispositivo de bloqueo del tubo y soporte orientable
Automatic with hose lock system and swivel bracket

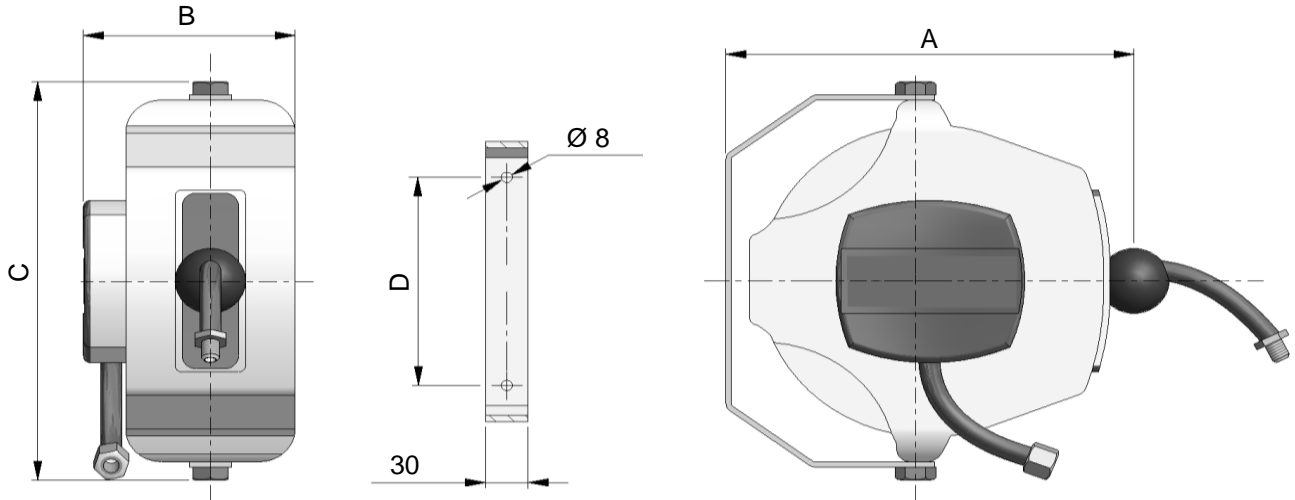

FLUIDO FLUID	MODELO MODEL	A	B	C	D	TUBO HOSE		PRESSION MAX MAX PRESSURE		CON TUBO WITH HOSE EURO
						Tipo/Type	m	bar	Mpa	
ARIA COMPRESSA COMPRESSED AIR	800					6x8	5			178,00
	801	300	150	300	160	6x10	10	10	1	199,00
	802	325	160	320	200	8x12	15	20	2	266,00
	803					10x15	20	15	1,5	434,00
	804					12x18	15	15	1,5	474,00