

MAX
40 l/min

W. P. 300 bar
Option 400 bar

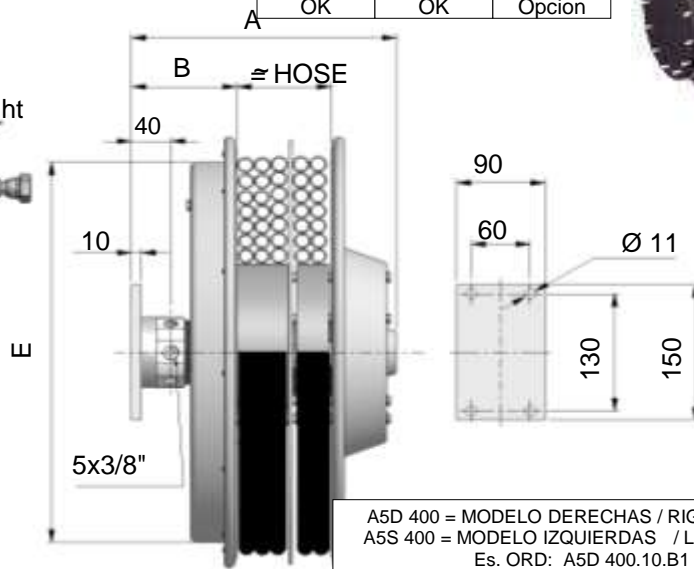
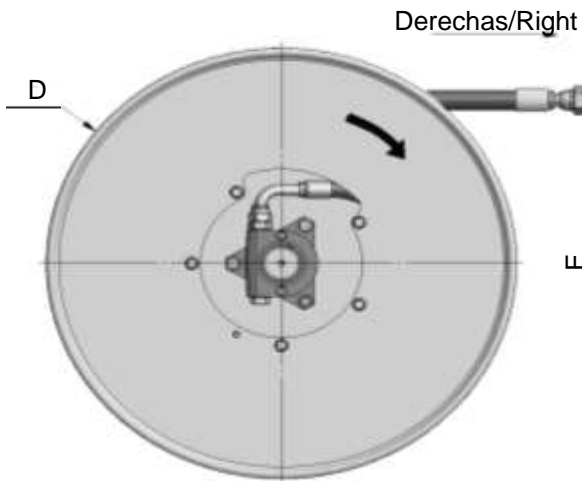
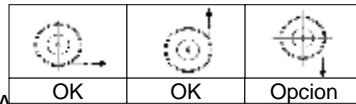

A5D 400 = MODELO DERECHAS / RIGHT MODEL
A5S 400 = MODELO IZQUIERDAS / LEFT MODEL
Es. ORD: A5D 400.10.B1

Modelo derechas Right model	A	B	D	E	sin tubo without hose EURO	Con tubo - with hose					
						Ø	Long.total	Long.util	R7	B1	B3
							Total length	Usable length	XX=R7	XX=B1	XX=B3
							m				
A5D295.06.XX	277	107	295	272	1000,00	1/4"	3,0	2,7	1170,22	1216,37	-
A5D295.08.XX						5/16"	2,3	2,0	1188,24	1215,19	-
A5D295.10.XX						3/8"	2,3	2,0	-	1233,47	1569,41
A5D320.06.XX	277	107	325	272	1014,00	1/4"	4,0	3,7	1217,56	1278,83	-
A5D320.08.XX						5/16"	3,2	2,9	1242,15	1281,20	-
A5D320.10.XX						3/8"	3,3	3,0	-	1312,49	1725,22
A5D340.06.XX	277	107	340	272	1052,00	1/4"	5,0	4,7	1289,87	1366,79	-
A5D340.08.XX						5/16"	4,2	3,9	1325,64	1378,10	-
A5D340.10.XX						3/8"	4,0	3,7	-	1396,64	1863,15
A5D370.06.XX	277	107	370	322	1158,00	1/4"	6,0	5,7	1430,56	1522,87	-
A5D370.08.XX						5/16"	5,3	5,0	1482,11	1549,30	-
A5D370.10.XX						3/8"	4,5	4,2	-	1536,15	2041,05
A5D400.06.XX	277	107	400	322	1205,00	1/4"	7,3	7,0	1521,03	1633,45	-
A5D400.08.XX						5/16"	6,5	6,2	1582,56	1665,79	-
A5D400.10.XX						3/8"	5,6	5,3	-	1654,62	2243,93
A5D420.06.XX	277	107	420	322	1325,00	1/4"	8,6	8,1	1685,12	1817,53	-
A5D420.08.XX						5/16"	8,0	7,5	1770,19	1873,54	-
A5D420.10.XX						3/8"	6,7	6,2	-	1846,72	2520,58

MAX
40 l/min

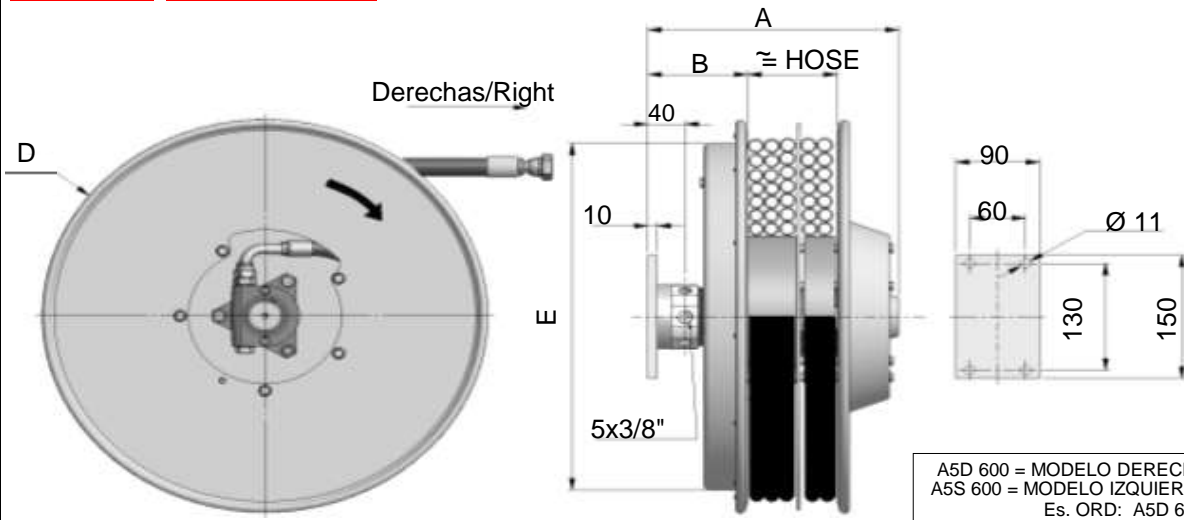
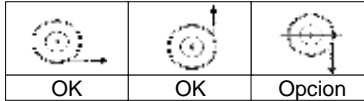
W. P. 300 bar
Option 400 bar

A5D 600 = MODELO DERECHAS / RIGHT MODEL
A5S 600 = MODELO IZQUIERDAS / LEFT MODEL
Es. ORD: A5D 600.10.B1

Modelo derechas Right model	A	B	D	E	sin tubo without hose EURO	Con tubo - with hose					
						Ø	Long.total	Long.util	R7	B1	B3
							Total length	Usable length	XX=R7	XX=B1	XX=B3
A5D470.06.XX	277	107	478	422	1460,00	1/4"	11,5	11,0	1921,01	2465,51	-
A5D470.08.XX						5/16"	10,0	9,5	1997,66	2501,33	-
A5D470.10.XX						3/8"	9,5	9,0	-	2549,45	3056,78
A5D520.06.XX	277	107	520	422	1637,00	1/4"	14,5	14,0	2199,76	2849,08	-
A5D 520.08.XX						5/16"	12,5	12,0	2287,32	2881,53	-
A5D520.10.XX						3/8"	11,2	10,7	-	2889,00	3475,43
A5D570.06.XX	277	107	570	422	1683,00	1/4"	17,5	17,0	2348,33	3081,03	-
A5D570.08.XX						5/16"	15,5	15,0	2469,43	3148,08	-
A5D570.10.XX						3/8"	13,5	13,0	-	3124,42	3849,64
A5D600.06.XX	277	107	620	532	1727,00	1/4"	21,0	20,5	2511,38	3339,79	-
A5D600.08.XX						5/16"	17,0	16,5	2580,80	3304,29	-
A5D600.10.XX						3/8"	16,0	15,5	-	3372,45	4249,62
A5D650.06.XX	277	107	650	532	1871,00	1/4"	22,5	22,0	2707,29	3597,92	-
A5D650.08.XX						5/16"	19,5	19,0	2838,91	3649,52	-
A5D650.10.XX						3/8"	17,5	17,0	-	3659,93	4608,31
A5D700.06.XX	277	107	720	532	2017,00	1/4"	27,0	26,5	3007,08	4035,93	-
A5D700.08.XX						5/16"	22,0	21,5	3098,20	3996,17	-
A5D700.10.XX						3/8"	20,0	19,5	-	4027,88	5110,85

MAX
40 l/min

W. P. 300 bar
Option 400 bar

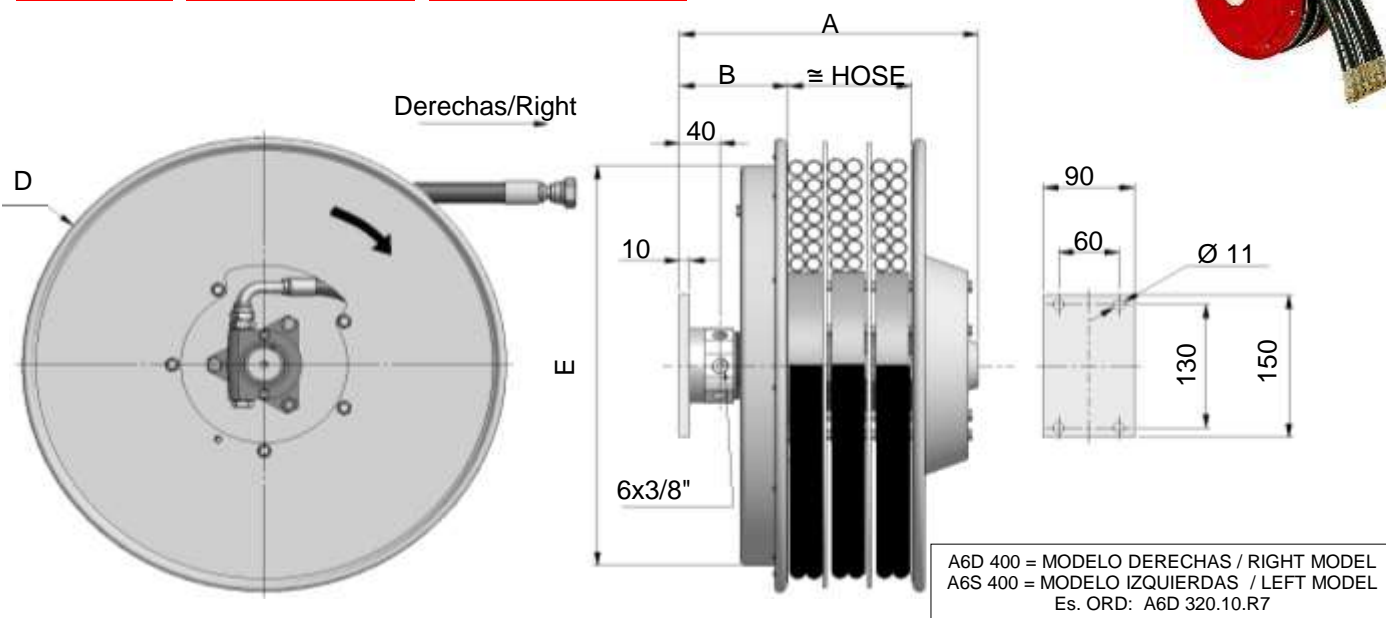
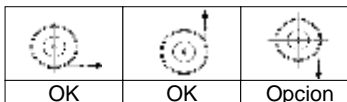
MAX HOSE SPEED
30 m/min

A6D 400 = MODELO DERECHAS / RIGHT MODEL
A6S 400 = MODELO IZQUIERDAS / LEFT MODEL
Es. ORD: A6D 320.10.R7

Modello destro Right model	A	B	D	E	senza tubo without hose EURO	Con tubo - with hose							
						Ø	Lungh. totale	Lung. utile	R7	R8	B1	B2	
							Total length	Usable length	XX=R7	XX=R8	XX=B1	XX=B2	
						m				EURO			
A6D295.06.XX	277	92	295	272	1000,00	1/4"	3,0	2,7	1205,72	1455,02	1281,46	1399,01	
A6D295.08.XX						5/16"	2,3	2,0	1235,70	1470,54	1295,92	1387,17	
A6D295.10.XX						3/8"	2,3	2,0	1233,73	1452,65	1278,70	1531,55	
A6D320.06.XX	277	92	325	272	1014,00	1/4"	4,0	3,7	1258,32	1569,94	1352,99	1494,99	
A6D320.08.XX						5/16"	3,2	2,9	1289,87	1583,35	1367,98	1479,21	
A6D320.10.XX						3/8"	3,3	3,0	1275,94	1531,28	1328,40	1605,83	
A6D340.06.XX	277	92	340	272	1052,00	1/4"	5,0	4,7	1335,89	1709,84	1449,50	1615,96	
A6D340.08.XX						5/16"	4,2	3,9	1379,28	1746,13	1479,87	1615,96	
A6D340.10.XX						3/8"	4,0	3,7	1372,05	1700,37	1439,51	1766,25	
A6D370.06.XX	277	92	370	322	1158,00	1/4"	6,0	5,7	1481,84	1918,11	1614,38	1805,30	
A6D370.08.XX						5/16"	5,3	5,0	1537,07	1977,28	1660,14	1821,08	
A6D370.10.XX						3/8"	4,5	4,2	1536,54	1937,84	1618,98	1995,03	
A6D400.06.XX	277	92	400	322	1204,00	1/4"	7,3	7,0	1547,59	2015,02	1689,59	1892,74	
A6D400.08.XX						5/16"	6,5	6,2	1634,37	2147,95	1779,92	1965,71	
A6D400.10.XX						3/8"	5,6	5,3	1640,55	2114,82	1737,98	2163,33	
A6D420.06.XX	277	92	420	322	1324,00	1/4"	8,6	8,1	1706,68	2236,44	1867,62	2095,22	
A6D420.08.XX						5/16"	8,0	7,5	1805,30	2392,25	1973,34	2183,98	
A6D420.10.XX						3/8"	6,7	6,2	1818,18	2365,43	1930,60	2405,27	

MAX
40 l/min

W. P. 300 bar
Option 400 bar

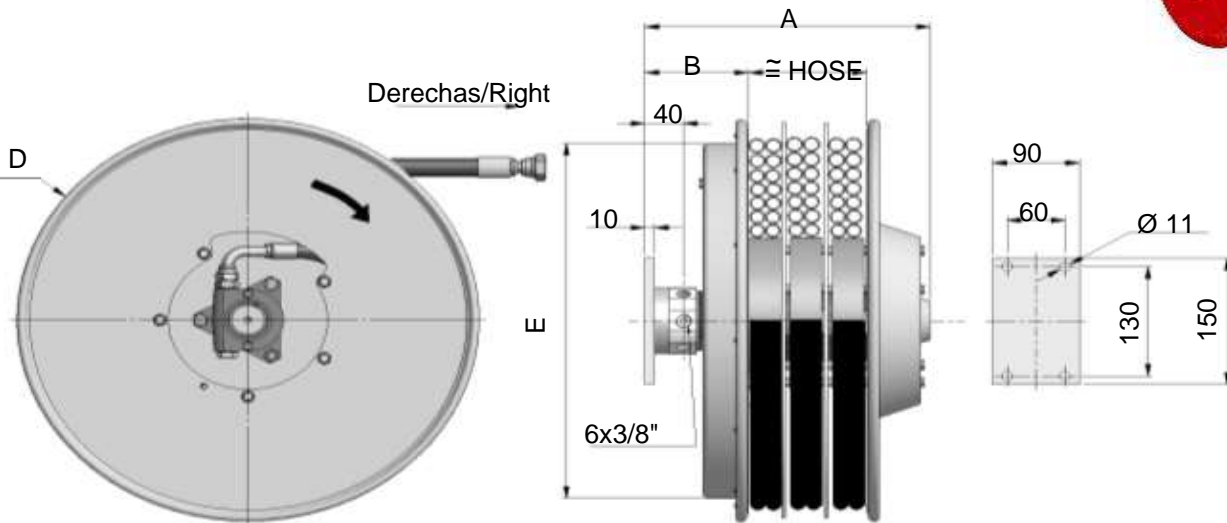
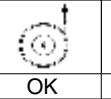
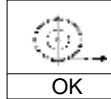
MAX HOSE
SPEED

A6D 470 = MODELO DERECHAS / RIGHT MODEL
A6S 470 = MODELO IZQUIERDAS / LEFT MODEL
Es. ORD: A6D 470.10.R7

Modelo derechas Right model	A	B	D	E	sin tubo without hose EURO	Ø	Con tubo - with hose					
							Long.total Total length	Long.util Usable length	R7 XX=R7	R8 XX=R8	B1 XX=B1	B2 XX=B2
							m		EURO			
A6D470.06.XX	277	92	478	422	1461,00	1/4"	11,5	11,0	1961,77	2678,49	2179,51	2480,48
A6D470.08.XX						5/16"	10,0	9,5	2070,24	2840,62	2294,56	2567,26
A6D470.10.XX						3/8"	9,5	9,0	2099,83	2829,57	2249,72	2847,72
A6D520.06.XX	277	92	520	422	1637,00	1/4"	14,5	14,0	2256,29	3160,00	2530,84	2905,18
A6D520.08.XX						5/16"	12,5	12,0	2400,27	3390,75	2692,04	3039,29
A6D520.10.XX						3/8"	11,2	10,7	2421,05	3333,16	2608,41	3329,61
A6D570.06.XX	277	92	570	422	1683,00	1/4"	17,5	17,0	2420,65	3511,33	2752,00	3199,70
A6D570.08.XX						5/16"	15,5	15,0	2548,85	3686,07	2885,58	3282,54
A6D570.10.XX						3/8"	13,5	13,0	2525,05	3510,14	2727,41	3497,91
A6D600.06.XX	277	92	620	532	1726,00	1/4"	21,0	20,5	2602,10	3910,91	2999,71	3533,02
A6D600.08.XX						5/16"	17,0	16,5	2669,16	3916,43	3039,55	3473,85
A6D600.10.XX						3/8"	16,0	15,5	2713,34	3880,93	2953,17	3847,01
A6D650.06.XX	277	92	650	532	1840,00	1/4"	22,5	22,0	2774,35	4176,64	3200,36	3770,35
A6D650.08.XX						5/16"	19,5	19,0	2910,44	4341,13	3337,11	3833,47
A6D650.10.XX						3/8"	17,5	17,0	2913,46	4190,45	3175,77	4143,51
A6D 700.06.XX	277	92	720	532	2017,00	1/4"	27,0	26,5	2971,58	4405,03	3407,06	3989,28
A6D700.08.XX						5/16"	22,0	21,5	3164,86	4705,61	3625,19	4158,89
A6D700.10.XX						3/8"	20,0	19,5	3293,85	4826,31	3608,62	4749,00