

.08	30 l/min
.10	30 l/min
.12	40 l/min
.16	60 l/min
.19	80 l/min
.26	135 l/min

W. P.
350 bar

MAX HOSE
SPEED

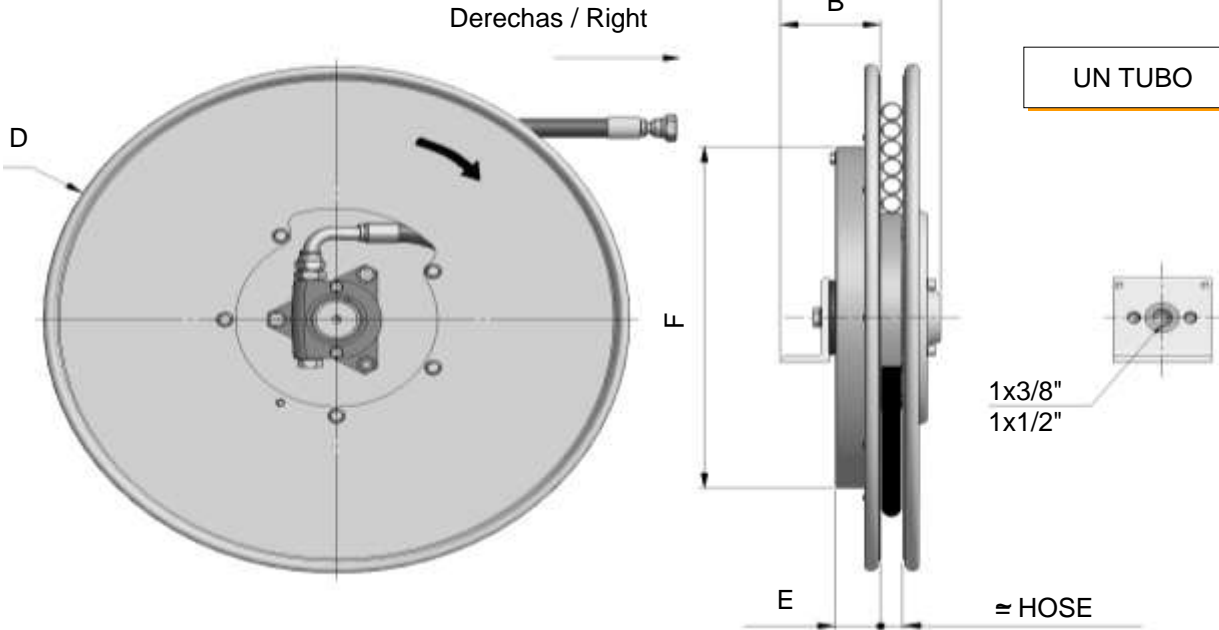
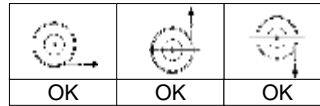

S1D 400 = MODELO DERECHAS/ RIGHT MODEL
S1S 400 = MODELO IZQUIERDAS / LEFT MODEL
Es. ORD: S1D 400.10.2SN

Modelo derechas	A	B	D	E	F	sin tubo	Tubo/Hose		Con tubo - with hose				
						without hose	Ø	Long.total	Long.util	SB1	1SN	2SN	4SP
Right model	mm					EURO		Total length	Usable length	XX=SB1	XX=1SN	XX=2SN	XX=4SP
							m	m	EURO	EURO	EURO	EURO	
S1D295.08.XX	150	82	295	37	272	413,00	5/16"	2,1	1,8	461,51	462,70	469,01	-
S1D295.10.XX							3/8"	1,5	1,2	457,18	456,78	461,65	491,62
S1D320.08.XX	150	82	325	37	272	420,00	5/16"	3,0	2,7	477,29	478,87	487,94	-
S1D320.10.XX							3/8"	2,5	2,2	475,19	474,53	482,68	532,65
S1D340.08.XX	150	82	340	37	272	431,00	5/16"	3,6	3,3	495,31	497,28	508,06	-
S1D340.10.XX							3/8"	2,7	2,4	489,26	488,60	497,41	551,45
S1D340.12.XX							1/2"	2,7	2,4	511,74	504,38	512,53	566,83
S1D370.08.XX	150	82	370	37	322	460,00	5/16"	4,3	4,0	531,47	533,70	546,72	-
S1D370.10.XX							3/8"	3,5	3,2	527,39	526,47	537,91	607,86
S1D370.12.XX							1/2"	3,0	2,7	545,40	537,12	546,19	606,54
S1D400.08.XX	150	92	400	47	322	472,00	5/16"	4,5	4,2	545,27	547,64	561,31	-
S1D400.10.XX							3/8"	5,0	4,7	556,32	555,00	571,44	671,37
S1D400.12.XX							1/2"	3,0	2,7	557,24	548,95	558,03	618,38
S1D420.08.XX	160	92	420	47	322	529,00	5/16"	6,0	5,7	617,19	620,35	638,49	-
S1D420.10.XX							3/8"	5,0	4,7	612,85	611,54	627,98	727,90
S1D420.12.XX							1/2"	5,0	4,7	645,33	631,53	646,65	747,23
S1D420.16.XX						736,00	5/8"	2,6	2,3	-	825,07	843,09	888,58
S1D470.08.XX	160	92	478	47	322	581,00	5/16"	8,5	8,2	695,43	699,90	725,67	-
S1D470.10.XX							3/8"	7,6	7,3	695,30	693,19	718,17	870,17
S1D470.12.XX							1/2"	6,5	6,2	721,59	703,71	723,30	854,13
S1D470.16.XX							5/8"	4,1	3,8	-	898,05	926,58	998,37
S1D470.19.XX						787,00	3/4"	2,7	2,4	-	894,23	908,70	959,85



.08	30 l/min
.10	30 l/min
.12	40 l/min
.16	60 l/min
.19	80 l/min
.26	135 l/min

WP
350 bar

MAX HOSE
SPEED

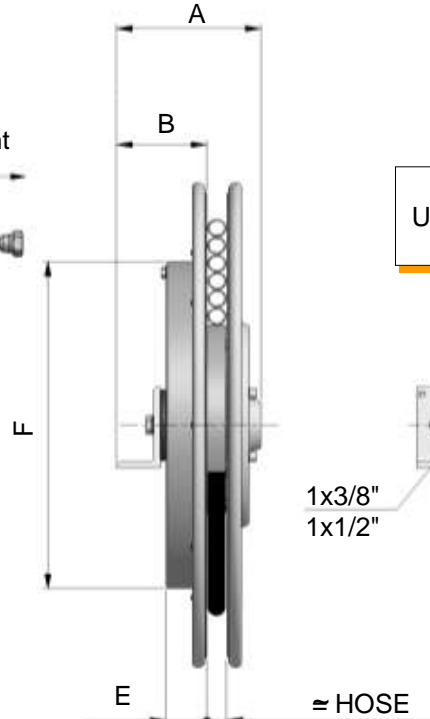
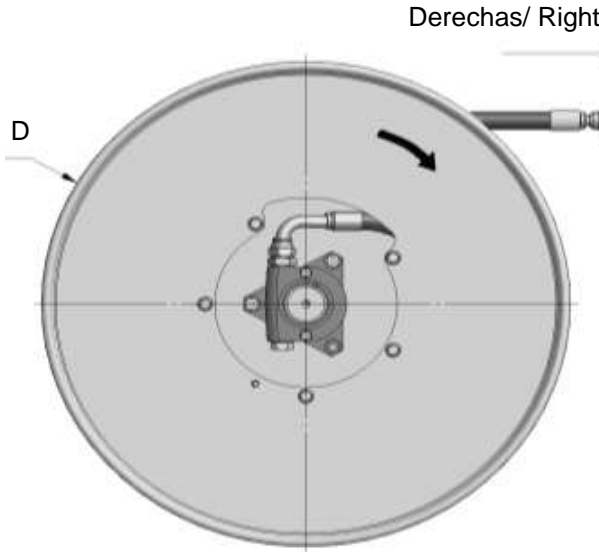
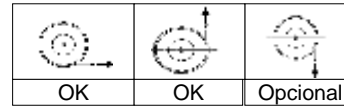

UNA ESPIRAL

1x3/8"
1x1/2"

S1D 520 = MODELO DERECHAS/ RIGHT MODEL
S1S 520 = MODELO IZQUIERDAS / LEFT MODEL
Es. ORD: S1D 570.10.2SN

Modelo derechas	A	B	D	E	F	sin tubo / without hose		Tubo/Hose		Con tubo - with hose				
						EURO	Ø	Long.total	Long.util	SB1	1SN	2SN	4SP	
								Total length	Usable length	XX=SB1	XX=1SN	XX=2SN	XX=4SP	
Right model	mm							m	m	EURO	EURO	EURO	EURO	
S1D520.08.XX			520			805,00	5/16"	10,0	9,7	934,39	939,60	969,84	-	
S1D520.10.XX								3/8"	9,3	9,0	938,33	935,78	966,29	1152,21
S1D520.12.XX								1/2"	8,2	7,9	972,00	949,33	974,18	1139,06
S1D520.16.XX								5/8"	5,0	4,7	-	1049,91	1084,76	1172,19
S1D520.19.XX								3/4"	4,2	3,9	-	1059,64	1082,26	1161,81
S1D520.26.XX						1625,00	1"	2,8	2,5	-	1788,86	1812,40	1873,14	
S1D570.10.XX			570			840,00	3/8"	11,0	10,7	993,17	990,22	1026,38	1246,22	
S1D570.12.XX								1/2"	10,0	9,7	1035,90	1008,23	1038,47	1239,65
S1D570.16.XX								5/8"	5,7	5,4	-	1110,66	1150,37	1250,17
S1D570.19.XX								3/4"	5,8	5,5	-	1138,93	1170,09	1280,01
S1D570.26.XX								1693,00	1"	4,4	4,1	-	1897,47	1934,42
S1D600.10.XX			620			881,00	3/8"	12,5	12,2	1051,16	1047,81	1088,83	1338,66	
S1D600.12.XX								1/2"	11,5	11,2	1100,33	1068,58	1103,30	1334,71
S1D600.16.XX								5/8"	7,5	7,2	-	1188,37	1240,57	1371,79
S1D600.19.XX								3/4"	7,0	6,7	-	1210,72	1248,46	1380,99
S1D600.26.XX								1761,00	1"	6,0	5,7	-	2004,63	2055,12
S1D650.10.XX			650			922,00	3/8"	14,8	14,5	1118,22	1114,21	1162,86	1458,70	
S1D650.12.XX								1/2"	13,8	13,5	1177,39	1139,32	1181,00	1458,57
S1D650.16.XX								5/8"	9,4	9,1	-	1331,95	1397,43	1561,92
S1D650.19.XX								3/4"	7,8	7,5	-	1339,84	1381,78	1529,57
S1D650.26.XX								1139,00	1"	6,3	6,0	-	2080,63	2133,62
S1D700.10.XX			720			1070,00	3/8"	18,5	18,2	1309,15	1304,21	1364,95	1734,69	
S1D700.12.XX								1/2"	14,5	14,2	1337,02	1296,97	1340,76	1632,53
S1D700.16.XX								5/8"	11,5	11,2	-	1418,20	1498,28	1699,45
S1D700.19.XX								3/4"	9,8	9,5	-	1430,30	1483,03	1668,68
S1D700.26.XX								1193,00	1"	8,4	8,1	-	2200,41	2271,02



.08	30 l/min
.10	30 l/min
.12	40 l/min
.16	60 l/min
.19	80 l/min
.26	135 l/min

W. P.
350 bar

MAX HOSE
SPEED

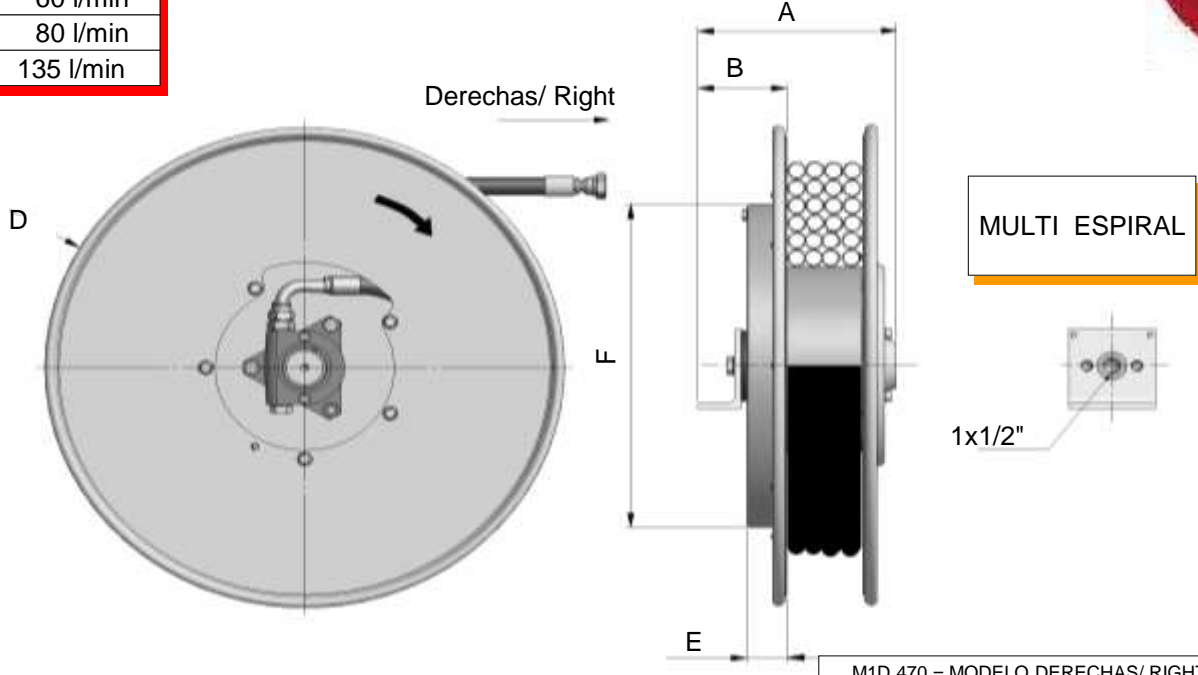
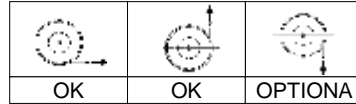

M1D 470 = MODELO DERECHAS/ RIGHT MODEL
M1S 470 = MODELO IZQUIERDAS / LEFT MODEL
Es. ORD: M1D 470.10.2SN

Modelo derechas	A	B	D	E	F	sin tubo without hose		con tubo - with hose							
						EURO	Ø	Longitud total - Total length (Util - Usable = - 0,5m)							
								XX = 1SN		XX = 2SN		XX = SB1		XX = R16	
Right model	mm							m	Euro	m	Euro	m	Euro	m	Euro
M1D295.06.XX			295			455,00	1/4"	4,7	527,65	3,5	525,42	5,5	528,57	4,7	541,20
M1D320.06.XX			325			462,00	1/4"	5,0	537,25	4,7	547,77	6,0	539,62	4,7	547,77
M1D320.08.XX				5/16"	4,5		537,12	4,0	543,82	5,0	539,88	4,5	550,79		
M1D320.10.XX				3/8"	4,5		538,96	4,0	546,45	4,5	540,14	4,5	553,69		
M1D340.06.XX			340			475,00	1/4"	5,5	555,53	5,0	564,86	6,0	552,77	5,5	571,44
M1D340.08.XX				5/16"	4,7		552,50	4,7	566,70	5,5	558,16	4,7	566,70		
M1D340.10.XX				3/8"	4,7		554,34	4,5	566,83	5,0	558,95	4,7	569,73		
M1D370.06.XX			370			506,00	1/4"	7,0	602,47	6,0	609,57	10,0	620,09	7,0	622,72
M1D370.08.XX				5/16"	7,0		608,78	5,5	609,30	9,0	625,61	7,0	629,95		
M1D370.10.XX				3/8"	6,0		600,36	5,0	605,62	9,0	636,26	6,0	620,09		
M1D470.06.XX			478			640,00	1/4"	15,5	823,76	14,5	855,45	16,0	807,85	15,5	868,59
M1D470.08.XX				5/16"	14,5		823,76	13,5	853,87	15,5	826,39	14,5	867,67		
M1D470.10.XX				3/8"	13,5		818,37	12,5	848,21	15,0	839,01	13,5	862,68		
M1D520.06.XX			520			886,00	1/4"	17,5	1090,15	16,0	1121,05	22,5	1111,84	17,5	1140,77
M1D520.08.XX				5/16"	16,5		1091,20	15,0	1120,39	21,5	1133,80	16,5	1141,16		
M1D520.10.XX				3/8"	15,5	1124,73	14,0	1153,92	21,5	1197,44	15,5	1175,61			
M1D520.12.XX				1/2"	13,5	1138,01	11,5	1146,69	16,0	1214,66	13,5	1178,77			
M1D570.08.XX			570			969,00	5/16"	17,5	1184,82	16,5	1224,00	18,5	1185,87	17,5	1237,81
M1D570.10.XX				3/8"	16,5		1180,61	16,5	1234,78	17,5	1196,39	16,5	1234,78		
M1D570.12.XX				1/2"	15,5	1256,08	14,5	1286,85	16,5	1314,59	-	-			
M1D600.10.XX			620			1070,00	3/8"	20,5	1326,56	-	-	26,0	1394,80	20,5	1393,88
M1D600.12.XX				1/2"	20,5		1375,08	-	-	26,0	1518,40	20,5	1437,01		
M1D700.12.XX			720			1179,00	1/2"	26,5	1562,31	23,5	1594,26	30,5	1698,53	26,5	1642,39

MAX
135 l/min

W. P.
350 bar

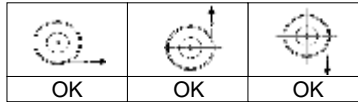
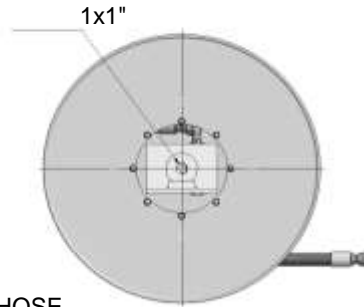
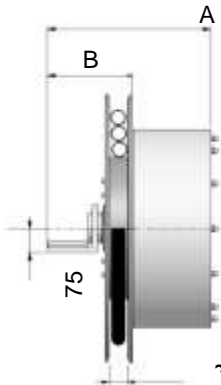
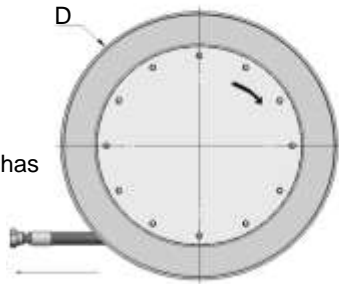
MAX HOSE
SPEED

VERSION "F"
Derechas
Right

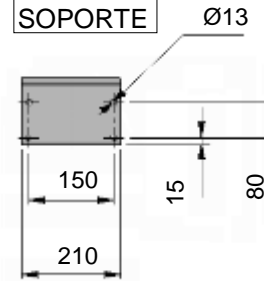
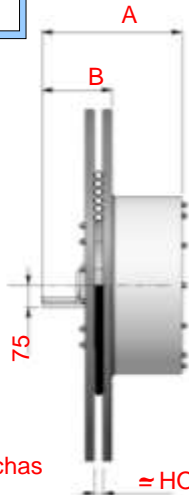
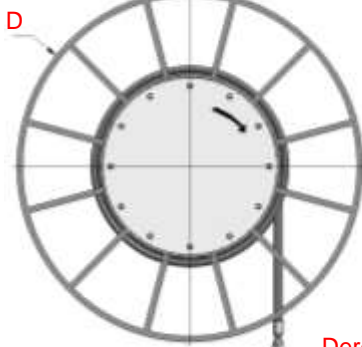
≈ HOSE

SOPORTE

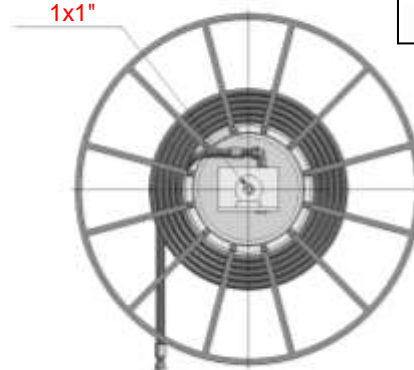
 A1D800 = MODELO DERECHAS/ RIGHT MODEL
 A1S800 = MODELO IZQUIERDAS / LEFT MODEL
 Es. ORD. A1D800.25.12.2SN

Derechas
Right

≈ HOSE

VERSION "R"

Modelo derechas Right model	Version	A	B	D	sin tubo without hose EURO	TUBO / WITH HOSE Con tubo - with hose						
						Ø	Long.total		2SN XX=2SN EURO	Long.util		4SP XX=4SP EURO
							Total length			Usable length		
							m					
A1D800.25.16.XX						5/8"	14,0	13,0	4.560	14,0	13,0	4.805
A1D800.25.19.XX	F	-	242	810	4198,00	3/4"	12,0	11,0	4.541	12,0	11,0	4.768
A1D800.25.25.XX						1"	10,0	9,0	4.627	10,0	9,0	4.844
A1D900.25.12.XX						1/2"	21,0	20,0	5.250	21,0	20,0	5.673
A1D900.25.16.XX	F	-	242	910	4875,00	5/8"	19,0	18,0	5.349	19,0	18,0	5.681
A1D900.25.19.XX						3/4"	17,5	16,5	5.348	15,0	14,0	5.573
A1D900.25.25.XX						1"	13,5	12,5	5.422	11,2	10,2	5.587
A1D1000.25.12.XX						1/2"	30,0	29,0	5.869	30,0	29,0	6.473
A1D1000.25.16.XX	R	-	242	1000	5350,00	5/8"	28,0	27,0	6.025	28,0	27,0	6.514
A1D1000.25.19.XX						3/4"	23,0	22,0	5.953	21,0	20,0	6.303
A1D1000.25.25.XX						1"	19,0	18,0	6.081	16,5	15,5	6.355
A1D1200.25.12.XX						1/2"	38,0	37,0	6.877	38,0	37,0	7.642
A1D1200.25.16.XX	R	-	300	1200	6230,00	5/8"	30,0	29,0	6.949	30,0	29,0	7.474
A1D1200.25.19.XX						3/4"	30,0	29,0	6.998	30,0	29,0	7.566
A1D1200.25.25.XX						1"	26,0	25,0	7.195	23,0	22,0	7.593
A1D1400.25.12.XX						1/2"	45,0	44,0	8.615	45,0	44,0	9.520
A1D1400.25.16.XX	R	-	300	1400	7855,00	5/8"	40,0	39,0	8.798	35,0	34,0	9.298
A1D1400.25.19.XX						3/4"	35,0	34,0	8.742	35,0	34,0	9.405
A1D1400.25.25.XX						1"	30,0	29,0	8.954	30,0	29,0	9.605
A1D1600.25.12.XX						1/2"	50,0	49,0	9.914	50,0	49,0	10.920
A1D1600.25.16.XX	R	-	300	1600	9074,00	5/8"	50,0	49,0	10.240	50,0	49,0	11.114
A1D1600.25.19.XX						3/4"	45,0	44,0	10.197	45,0	44,0	11.049
A1D1600.25.25.XX						1"	40,0	39,0	10.508	40,0	39,0	11.376